



火焰防阻器

Atlas Flame Arresters

豐 映 科 技 股 份 有 限 公 司

RESI Corporation / Atlas Energy Systems Limited

防爆型火焰防阻器 Atlas Detonation Flame Arrester

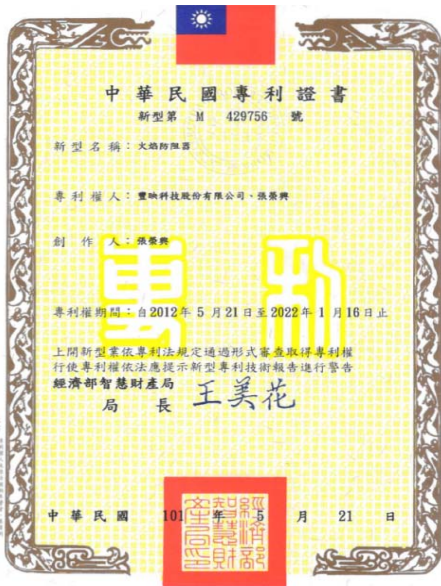

Atlas火焰防阻器展現最優秀的火焰防護性能；發生火焰時，能利用專利的細金屬網及粉體填充元件的結構特性，有效吸收及分散火焰能量防止火焰繼續蔓延。對於桶槽排氣口、各種管路系統及輸送長度，Atlas火焰防阻器都能提供有效的保護；在大流量系統依然能保持最佳安全防護。

Atlas火焰防阻器利用創新的專利防火元件冷卻火焰波，同時使用雙向爆炸衝擊波緩衝器削弱爆炸、爆燃所產生的高速及高壓衝擊波。Atlas火焰防阻器以獨特的設計方式，提供較大的火焰通道，使得元件例行性保養頻率明顯減少，並使保養清潔工作更簡便；同時利用創新設計的火焰防阻元件，使對應於相同壓降的流量最大化，增加產品使用價值。

Atlas火焰防阻器可應用於複雜的管路、較長管路系統中，阻斷爆炸、超爆炸所產生的高壓、高速度火焰；也可以應用在開放及封閉系統，在各種壓力條件下都可以防止爆燃蔓延。Atlas火焰防阻器均為雙向防護設計，任何安裝方向均可阻擋次音速或超音速傳遞的揮發性混合氣體火焰。

Atlas火焰防阻器接續口設計成標準法蘭型式或標準牙口，使得內置防火元件的保養、更換能快速輕易的完成，不需更動配管管路。標準外部構件為碳鋼或不鏽鋼，主要防火元件則使用SUS-304、SUS-316或SUS-316L不鏽鋼製作而成。對於特殊應用需求則可選用特殊材料製作或採用塗佈保護。



RESI Patented In-line Detonation Flame Arrester

(中華民國新型專利M429756 · 2012)

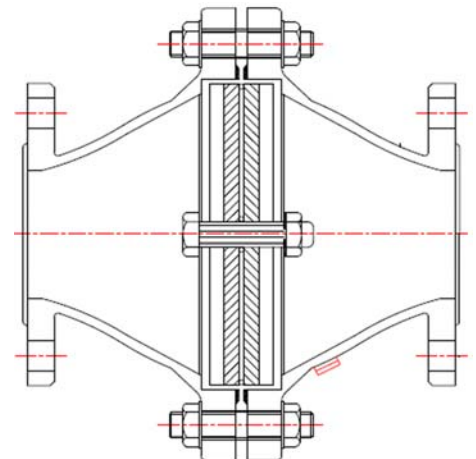

Deflagration Flame Arrester

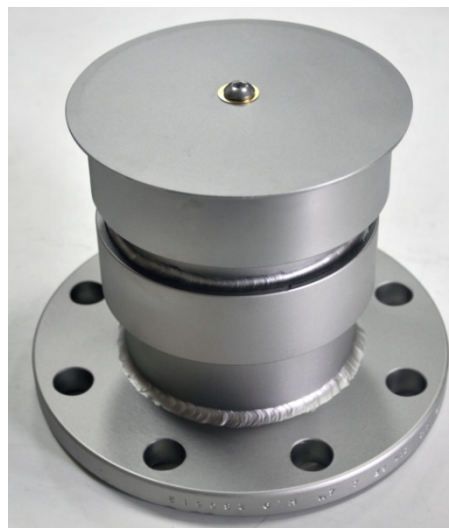

RESI End of Line Flame Arrester



End of Line Flame Arrester, with Automatic Flare, was developed by RESI for Laboratory Applications.

防爆型火焰防阻器 Atlas Detonation Flame Arrester

The Atlas Flame Arrester represents the best value in flame arrester protection. They prevent flame propagation by absorbing and dissipating heat using patented mesh wound and powder filled flame cells. These patented cells allow maximum flow with maximum protection. They provide protection against flame propagation in piping systems that are manifold or have long run-up distances. Atlas utilizes an innovative shock wave damping element assembly that dampens the high velocities and pressures associated with deflagrations and detonations while quenching the flame front.

Our design is unique in the ability to provide larger flame channels which requires less frequent maintenance and greater ease in cleaning when service is required. Our innovative element offers maximum flow to pressure drop characteristics enhancing the value of our product in any system. They are typically used for extended pipe length or multiple pipe bend configurations to stop high pressures and flame velocities associated with detonations and overdriven detonations. In addition, it stops confined and unconfined, low and high pressure deflagrations. All Atlas units are bi-directional and are proven to stop an ignited flammable vapor mixture approaching from either direction that can be traveling at subsonic or supersonic velocities.

With standard flanged connections, this Arrester provides the option of the removal of the flame cell element for easy cleaning and replacement without disconnecting of the pipe connection.

Standard housing construction is carbon steel and stainless steel. The element is available in SUS-304 · SUS-316 or SUS-316L. Special construction material and coatings are available on request.

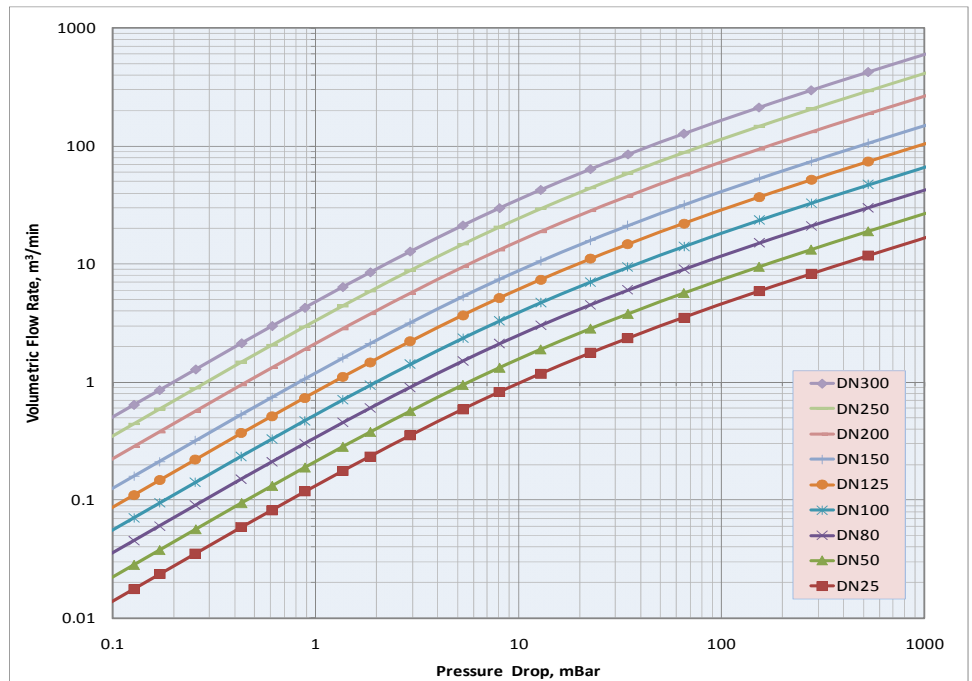

Features and Benefit

- All Atlas Detonation Flame Arrestors are designed for unstable detonations.
- Removable Element design allows for easy inspection, cleaning and replacement.
- Atlas's laminated matrix provides:
 - Maximum flow
 - Less Pressure Drop
 - Easy Cleaning
 - Less Clogging
 - Less Maintenance
 - Bi-directional Design
- Design
 - In-line deflagration, detonation and short time burning flame arrester
 - End of line deflagration flame arrester.
- Available in ANSI, DIN and JIS flanges.
- Nominal Diameter
DN25, DN32, DN40, DN50, DN65, DN80,

- DN100, DN125, DN150, DN200, DN250, DN300
- Connection
ANSI B16.5 – 150 RF, 300 RF
JIS-10K RF, JIS-20K RF
- Applications
gas, gas/air, or vapor/air mixture of explosive groups
 - ✧ I (methane) MESG ≤ 1.14 mm
 - ✧ IIA (D) MESG ≤ 0.90 mm
 - ✧ IIB3 (C) MESG ≤ 0.65 mm
 - ✧ IIC (B) MESG < 0.50 mm
- Material
 - Metal Cell Element:
Stainless Steel 304, Stainless Steel 316, Hastelloy
 - Body:
Carbon Steel, Stainless Steel 304, Stainless

- Steel 316, Hastelloy
- Painting:
 - Optional PVDF coated unit provides outstanding corrosion and chemical resistance.
 - Optional Zinc coated unit provides outstanding corrosion and chemical resistance for semiconductor industry.
- Temperature Sensors: (Option)
Resistance thermometer with protective type
- Inherently safe (EEx i)
- Protected against explosion (EEx d)
- Pressure Sensors: (Option)
- Guidance
EC guide line 94/9/EC with ATEX95 and EN12874
- 中華民國新型專利M429756 · 2012

Key to ATLAS Detonation Flame Arrester (DFA) Model Number:

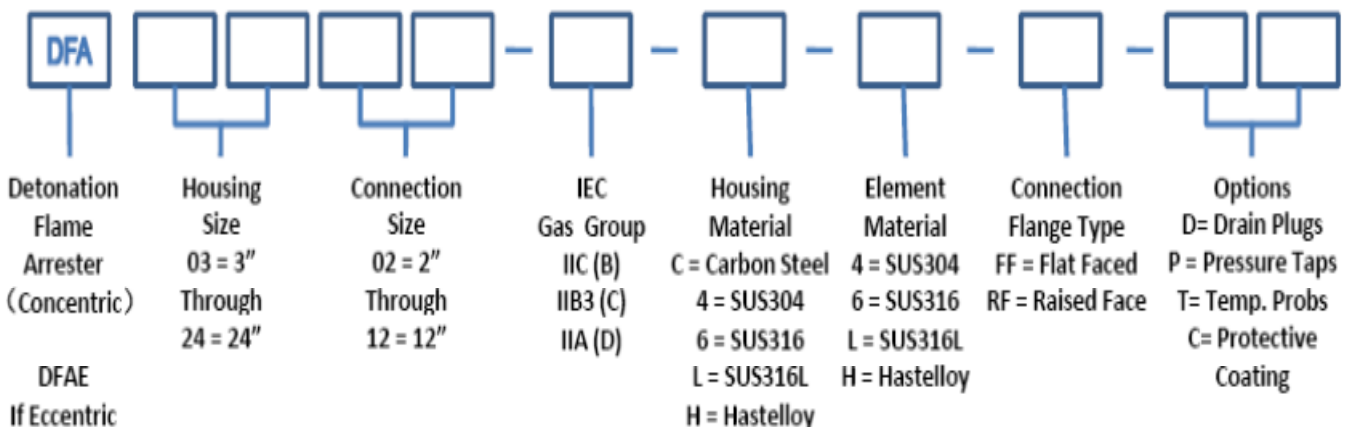

法蘭洩漏防護型火焰防阻器

Atlas Flame Arrestor for flange leakage protection

Atlas法蘭洩漏防護型火焰防阻器提供法蘭洩漏最有效的火焰防護性能；發生火焰時，能利用上護蓋的多孔狀防火元件的結構特性，有效吸收及分散火焰能量防止火焰經由法蘭洩漏處蔓延進管道。對於各種管路系統，Atlas法蘭洩漏防護型火焰防阻器都能提供有效的保護；在大口徑系統依然能保持最佳安全防護。



Atlas法蘭洩漏防護型火焰防阻器利用創新的防火元件冷卻火焰波，同時削弱爆燃所產生的高速及高壓衝擊波。Atlas法蘭洩漏防護型火焰防阻器以獨特的設計方式，提供較大的火焰通道，使得元件例行性保養頻率明顯減少，並使保養清潔工作更簡便；同時利用創新設計的火焰防阻元件，使對應於相同壓降的流量最大化，增加產品使用價值。

Atlas法蘭洩漏防護型火焰防阻器可應用於複雜的管路系統中，阻斷燃爆所產生的高壓、高速度火焰；可以應用在各種壓力條件下操作的管道，以防止爆燃蔓延。

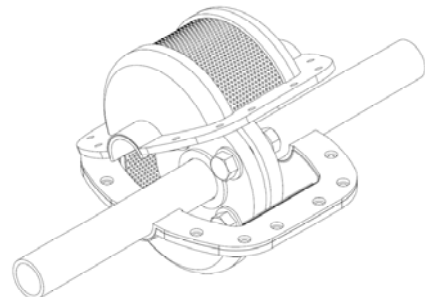

Atlas法蘭洩漏防護型火焰防阻器接續口設計成法蘭型式，使得內置防火元件的保養、更換能快速輕易的完成，不需更動配管管路。標準外部構件為碳鋼或不鏽鋼，主要防火元件則使用304、316不鏽鋼製作而成。對於特殊應用需求則可選用特殊材料製作或採用塗佈保護。

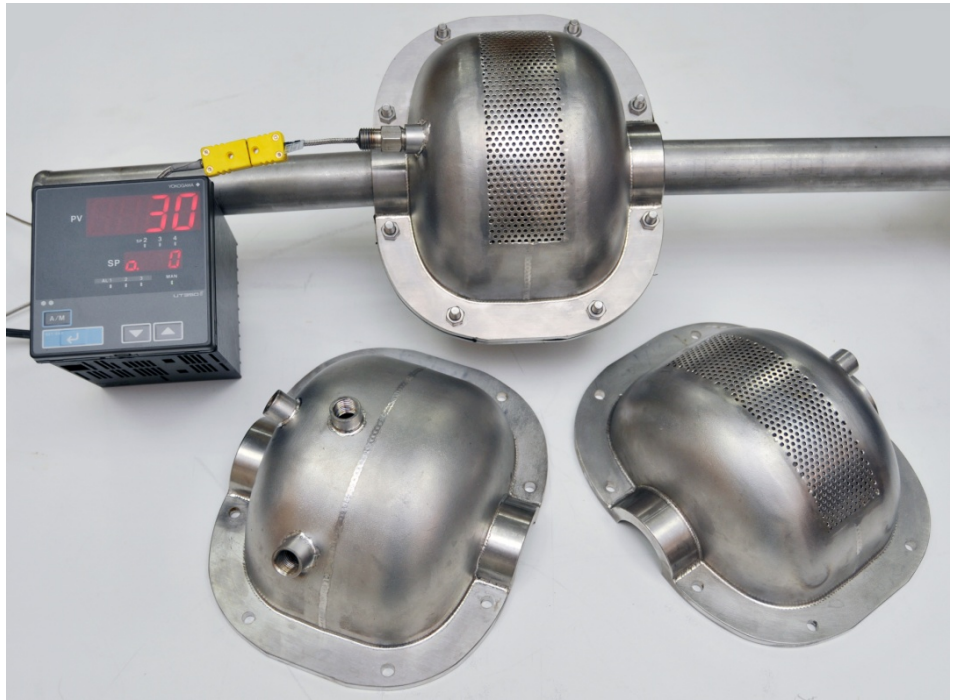

The Atlas Flame Arrestor for flange leakage protection represents the best value in flame arrestor applications. They prevent flame propagation by absorbing and dissipating heat using laminated mesh wound cells. These cells allow maximum flow with maximum protection. They provide protection against flame propagation from ambient to the piping system. Atlas utilizes an innovative element assembly that dampens the high velocities and pressures associated with deflagrations while quenching the flame front.

Our design is unique in the ability to provide larger flame channels which requires less frequent maintenance and greater ease in cleaning when service is required. Our innovative element offers maximum flow to pressure drop characteristics enhancing the value of our product in any system. They are typically used for pipe networks to stop high pressures and flame velocities associated with deflagration flame.

Designed with flanged connections, this Arrestor provides the option of the removal of the flame cell element for easy cleaning and replacement without disconnecting of the pipe connection.

Standard housing construction is carbon steel and stainless steel. The element is available in 304 S.S and 316 S.S. Special construction material and coatings are available on request.



法蘭洩漏防護型火焰防阻器

Atlas Flame Arrestor for flange leakage protection

Features and Benefits

- All Atlas Flame Arrestors for flange leakage protection, are designed for deflagrations.
- Laminated element design allows for easy inspection, cleaning and replacement.
- Atlas's laminated matrix provides:
 - Maximum flow
 - Less Pressure Drop
 - Easy Cleaning
 - Less Clogging
 - Less Maintenance
 - Bi-directional Design
- Available for the protection of ANSI, DIN and JIS flanges as well as sewage lock connections.
- Nominal Diameter



- DN25, DN32, DN40, DN50, DN65, DN80, DN100, DN125, DN150, DN200, DN250, DN300
- Applications
 - gas, gas/air, or vapor/air mixture of explosive groups
 - I (methane) MESH ≤ 1.14 mm
 - IIA (D) MESH ≤ 0.90 mm
 - IIB3 (C) MESH ≤ 0.65 mm
 - IIC (B) MESH ≤ 0.50 mm
- Material
 - Metallic Cell Element: Stainless Steel 304, Stainless Steel 316, Hastelloy
 - Body: Carbon Steel, Stainless Steel 304, Stainless Steel 316, Hastelloy
- Painting or Coating:
 - Optional PVDF coated unit provides outstanding corrosion and chemical resistance.
 - Optional Zinc coated unit provides outstanding corrosion and chemical resistance for semiconductor industry.

- Sensors: (Option)
 - Resistance thermometer with protective type
 - Pressure Sensor
 - VOC sensor
 - Inherently safe (EEx i)
 - Protected against explosion (EEx d)

- Guidance
 - EC guide line 94/9/EC with ATEX95 and EN12874
 - ROC Patent M429791, 2012

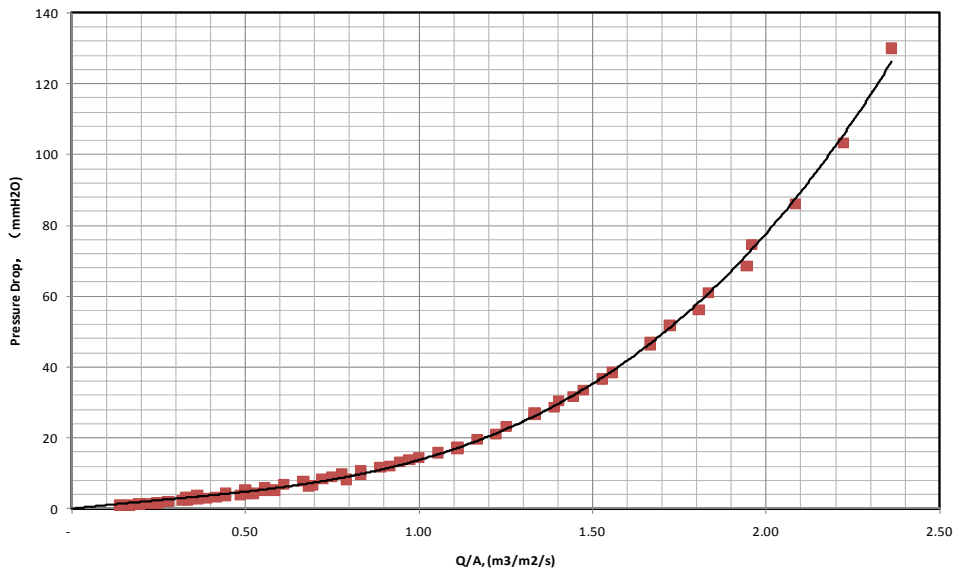

Key to ATLAS Flame Arrestor for the protection of flange leakage (FFA) Model Number:

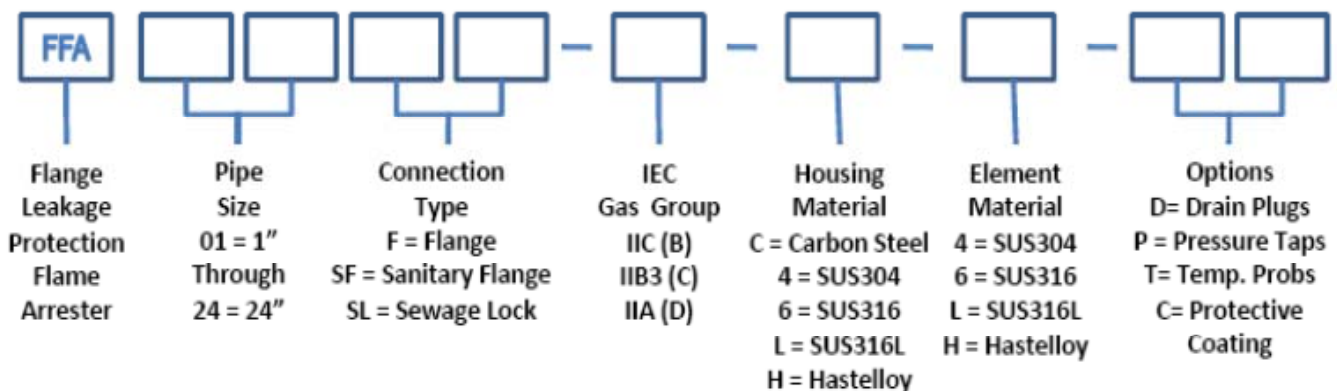

火焰防阻器技術

Flame Arrester Technology

本文件為火焰防阻器的簡要介紹及本公司設備型錄，並說明可燃性氣體的分類、火焰防阻器的分類、用途與規範。有關火焰防阻器的選擇與使用，歡迎洽詢豐映科技股份有限公司。

This document provides an introduction to flame arresters, including their construction and how they work, and provides useful notes explaining different flame types and where they are used, as well as the different types of gases and vapours. For comprehensive technical advice regarding the selection and use of flame arresters, please contact Atlas Energy Systems.

豐映科技股份有限公司

Atlas Energy Systems Limited

40865 台中市南屯區文心路一段 218 號 21 樓

<http://www.resi.com.tw> E-mail: service@resi.com.tw

Tel: +886-4-2472-6600 Mobile: +886-987-070-398



火焰防阻器是一種安裝在管道間、管道末端、桶槽排氣口等處所的設備，在正常使用狀態可讓氣體或蒸氣通過，但是一旦發生火災時，可有效阻隔火焰，避免設備遭受傷害。Atlas 特別提供一種可以保護法蘭洩漏的火焰防阻器，可防止火焰因法蘭洩漏而蔓延進管道。

在本文件中，只考慮火焰在空氣中燃燒的情況（使用純氧燃燒需考慮其它問題），且所介紹之火焰防阻器僅限於本身沒有可移動元件的被動式設計。

A flame arrester is a device fitted to the opening of an enclosure or to the connecting pipe work in a system of enclosures and which permits gases or vapours to flow under normal operating conditions but prevents the transmission of a flame should an ignition take place. A flame arrester for flange leakage protection has been developed for the preventing flame propagation to pipe work through flange.

In this guide, consideration is limited to flame arresters for use where the flame burns in air (not in oxygen where there are special problems). Furthermore, the guide is restricted to passive flame arresting devices with no moving part.



什麼是火焰防阻器？

What is a Flame Arrester?



輸送及儲存易燃液體或氣體時，最危險的事情就是發生蒸氣被點燃而造成火災或爆炸；本文件介紹火焰防阻器的基本知識、其規格及應用的基本原理與觀念。如需更詳細的瞭解，可洽詢豐映科技股份有限公司取得詳細的技術諮詢及支援。

可燃性氣體或蒸氣與空氣/氧氣混合，就有燃燒或爆炸的潛在風險。意外點燃可燃氣，會導致火焰經未燃盡的混合物傳遞，直到燃料反應耗盡為止。在密閉空間，例如容器或管道中發生燃燒時，燃燒產物會因溫度反應而急速升溫，導致氣體體積快速增加，伴隨產生的壓力升高引起紊流，會進一步將火焰波加速。

One of the greatest dangers involved with the transportation or storage of flammable liquids or gases is that ignition of the flammable vapor may occur, resulting in fire or an explosion. This document introduces the flame arresters, and the principles and concepts behind their specification and use. For those seeking a more detailed understanding, full technical advice and support is available from RESI.

Whenever a flammable gas or vapor is mixed with air/oxygen, there is the potential for a fire or an explosion. Accidental ignition of the flammable mixture will result in a flame that will travel through the unburnt mixture until the fuel is consumed by the reaction. In an enclosed space, such as a vessel or a pipe, the significant temperature increase of the mixture caused by the combustion process will lead to a rapid increase in the volume of the gas mixture. The resulting increase in pressure will induce turbulent effects which will further accelerate the flame front.

A flame arrester is a safety device whose principal purpose is to prevent a flame entering or leaving a pipe or vessel or to prevent it travelling further down a pipe. In many cases it is used in conjunction with other components to create a safety system. Failure to stop a flame can result in catastrophic damage to equipment, loss of production, injury to people and even loss of life and potentially large litigation costs.

There are different types of flame arrester, each of which is designed to handle certain conditions. It is essential that the flame arrester is correctly specified to ensure that a flame is extinguished (or properly contained) and that an explosion is prevented from propagating through the equipment.



火焰防阻器是一種安全裝置，其主要目的是防止火焰進出管道和容器，或防止它進一步地沿著管道蔓延。在許多情況下，它與其他元件一起使用，以建立一個安全的系統。未能有效阻止火焰，將導致災難性的設備損壞、停產損失、人員傷亡及潛在且巨大的訴訟成本。

火焰防阻器有多種不同的類型，分別有其特定用途。正確地選用火焰防阻器，才能確保火焰在設備間傳遞時，能有效的將火焰熄滅。

選用火焰防阻器的第一個步驟，是要先確定潛在的點火源位置。只有先確定點火源，才有辦法開始去瞭解要保護什麼及要如何保護。

The first step in specifying a flame arrester is to determine the location of the potential ignition source. Only when this has been established can one start to understand what is to be protected and how.

火焰的種類 Types of Flame



heating purposes. Problems with the boiler or the pumping system could ignite the pipe contents and the flame could travel back down the pipe resulting in an explosion below ground.



不受限的爆燃

無法控制的爆燃，通常是因為在容器或設備外部的易燃氣體被點燃而發生。

例如儲油槽的排氣口或呼吸閥附近可能會產生局部的易燃氣體雲；如果有火源，如雷擊、香菸或靜電，都可能引燃蒸氣，使得火焰波經由桶槽出口進入槽體內引發爆燃。

Unconfined Deflagration

An unconfined deflagration occurs when there is an ignition of flammable gases outside a container or process equipment. For example, a breathing or ventilation valve from a tank storing volatile liquid may produce an unconfined cloud of flammable vapor in its immediate vicinity. Any ignition sources such as a lightning strike, a lit cigarette or a static electrical discharge could ignite this vapour cloud and the resulting flame front may enter the tank through the outlet.



受限的爆燃

在管道中的可燃性混合氣體被點燃時，火焰波前將以次音速的速度沿著管道傳遞，稱為受限的爆燃。

這種情況可能發生在科技產業工廠、化工廠及各種工業；例如，許多地下煤礦產生易燃性或有毒的甲烷氣體，常利用送風機經管道輸送，供應鍋爐加熱。鍋爐或輸送系統發生問題時，可能點燃管道內的可燃性氣體，並沿著管道回火，造成地面下的爆炸。



Confined Deflagration

When a flammable mixture in a pipeline is ignited, the flame front will travel along the pipe at subsonic velocities initially in what is known as a confined deflagration. Typically this could occur in industrial or process plant. For example, many coal mines generate flammable and poisonous methane gas below ground which is pumped to the surface along a pipe and then burnt in a boiler for

爆轟 Detonation

火焰沿著管道引爆時，經過一段距離後，會以超音速的速度傳遞並產生衝擊波。這種情況通常是因為粗糙不平的管壁、彎曲的障礙物、閥門及管道尺寸的變化引起亂流，使得火焰加速所致。火焰沿著管道持續加速一段足夠的距離，也可能發生爆炸。衝擊波是火焰速度由亞音速轉變為超音速時，氣體壓力和密度劇變而產生。

A detonation occurs where a flame travels along a pipe, usually at supersonic velocities and is combined with a shock wave. Typically this occurs as a result of turbulence-induced flame acceleration caused by roughness in the pipe walls or interruptions such as bends, valves or changes in section of the pipe. It can also occur simply by allowing the flame to continue to accelerate along a pipe for a sufficient distance. A shock wave is characterized by a step change in pressure and density through which the flame velocity changes from being subsonic to supersonic.

火焰發生的條件 Flame Propagation

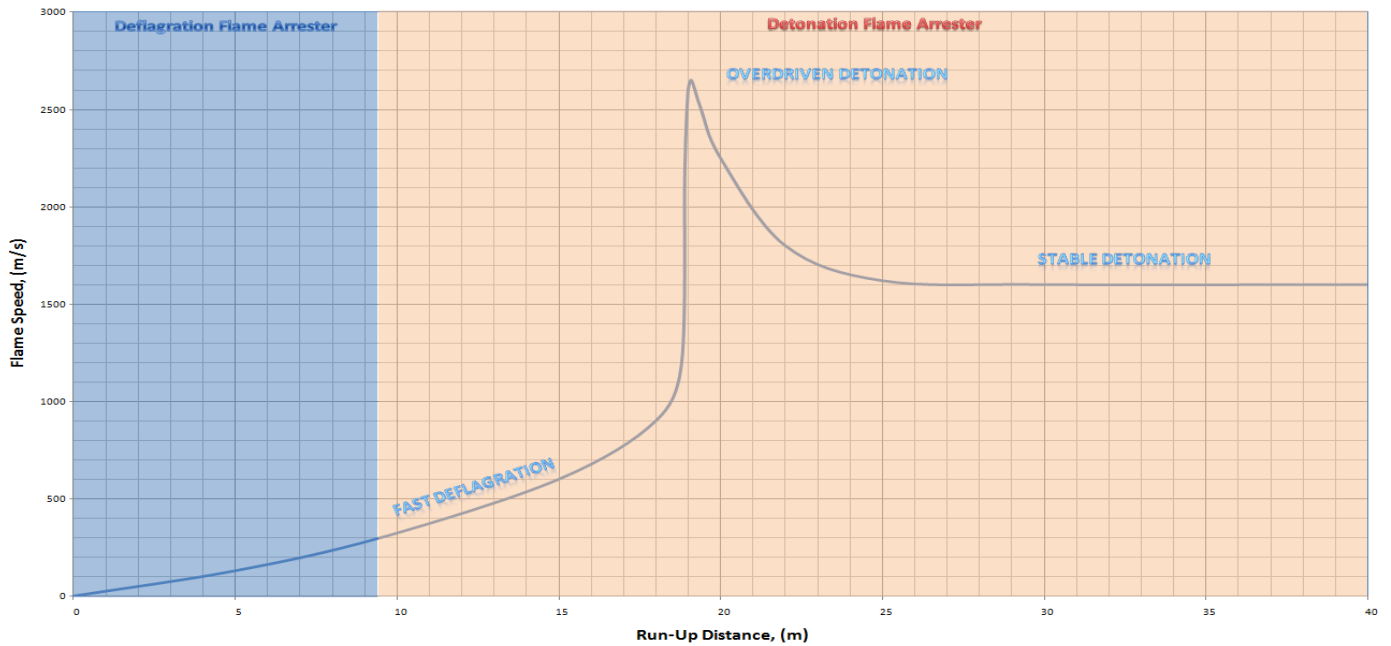

常溫常壓的碳氫化合物在管徑 200 毫米的直管中點燃，並使火焰前端不受干擾進行燃燒時所發生的典型情況。

上圖顯示，常溫常壓的碳氫化合物在管徑200毫米的直管中點燃，並使火焰前端不受干擾的燃燒時，所發生的情況。由圖可見火焰開始緩慢爆燃(火焰速度小於每秒300米)，然後加速進入快速爆燃(處於亞音速約每秒500米以下)。對於碳氫化合物，當點火源是在50倍管徑以內時，建議使用爆燃型火焰防阻器(氫氣則為30倍管徑以內)；此距離會隨著系統壓力升高而縮短。

其後，火焰由燃爆快速的轉換成爆炸。此時，火焰速度將較最初緩慢的燃爆速度高出一個數量級，達到約每秒2500米。這代表火焰波前與對應的壓力波達到最壞的情況，成為超爆燃或不穩定爆炸。在這種情況下必須安裝適當設計的防爆型防阻器。

It can be seen from Figure shown above that the flame begins as a slow deflagration (flame speed < 300 m/s), but accelerates into a fast deflagration (still at subsonic velocities ~ 500 m/s). It is recommended that a deflagration arrester is fitted for situations in which the ignition source is within 50 pipe diameters of the arrester for hydrocarbon gases (within 30 pipe diameters for hydrogen), although this distance is reduced for systems at pressures above atmospheric.

The flame then undergoes a rapid and sudden transition from deflagration to detonation. Under these conditions, the flame may accelerate to a velocity an order of magnitude higher than the initial slow deflagration (~ 2500 m/s). This represents the worst case conditions for the flame front and the associated pressure wave and is known as an overdriven detonation, or an unstable detonation. In such circumstances, a suitably designed unstable detonation arrester must be fitted.



火焰繼續往前蔓延，不穩定爆炸會逐漸減速成為較不嚴重的穩定爆炸，然而這種狀態也可能會突然進一步轉變為不穩定爆炸；例如，管道內表面的粗糙不平，突出的墊片或儀表連接處及彎管與收縮閘等也可能再度引發不可預知的不穩定爆炸。由於這種不可預測性，大部分製造商會建議在此處安裝不穩定爆炸火焰防阻器，但有少數廠商則冒險建議安裝穩定防爆防阻器，但本公司不建議採用。



An unstable detonation will degrade to a less severe stable detonation as the flame proceeds further down the pipe. However, such flame fronts may suddenly undergo further transitions to unstable conditions. These events are unpredictable, and are caused by anything that may increase the turbulence of the system, including roughness in the inside surface of the pipe, or a protruding gasket or instrument port as well as bends or constrictions due to valves. Because of this unpredictability, most flame arrester manufacturers recommend that an unstable detonation arrester is fitted in the pipe. A few manufacturers will take the risk of fitting a stable detonation arrester under such circumstances, but this is not recommended by RESI.

氣體和蒸汽的類型 Types of Gas and Vapor

氣體和蒸氣的可燃性以及爆炸性各有不同。特定氣體組成與空氣混合產生爆炸的相對嚴重程度，可以利用多種氣體的特性表示，包含：爆炸的上限及下限(LEL/UEL)、自燃溫度(AIT)、最小引火能量(MIE)、最低需氧濃度(LOC)以及最大試驗安全間隙(MESG)。

為了便於評估，純氣體可依其反應的相似性分組。依資訊來源不同有幾種分組方式，其中以表1和表2所示兩種分類最廣泛使用。在這些表中，氣體組別是由MESG值的範圍來區分，表中所列典型的測試氣體可供火焰防阻器之類別測試。

若一火焰防阻器經測試可供一氣體組別使用，則對於同一組的其他氣體或是較低組別的氣體均可適用。例如，在實務上，丙烷可作為火焰防阻器的最低測試標準氣體，若經測試通過，就代表它可以運用在IIA組、I組或是甲烷氣體上使用。其他標準也將氣體做類似分組，但其分類可能不盡相同。

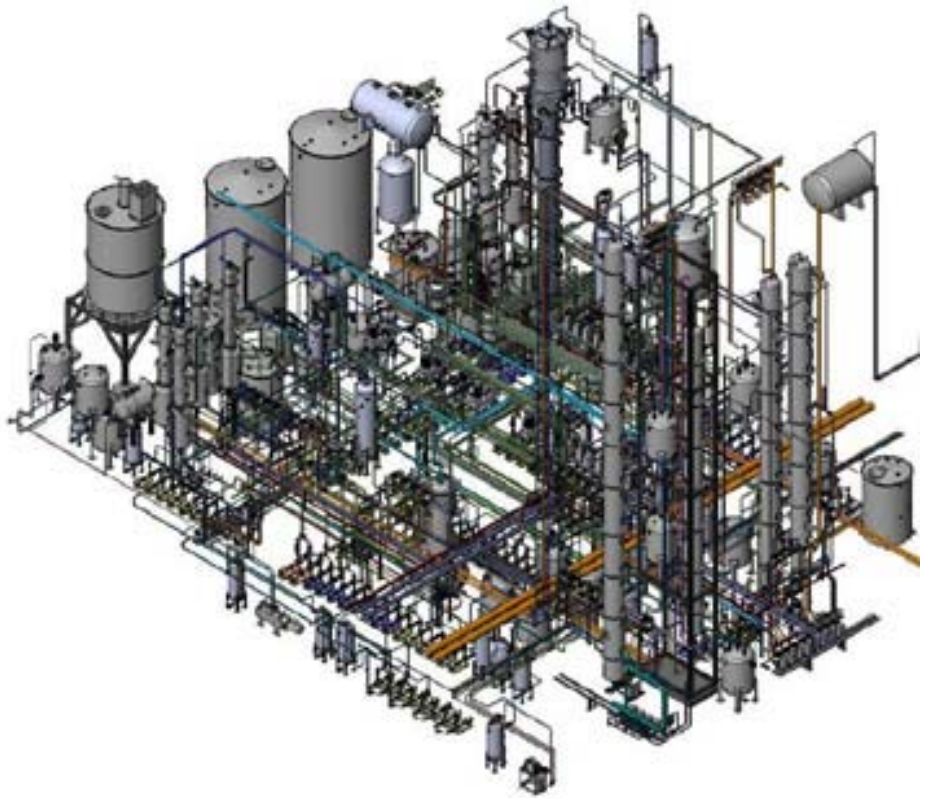

Gases and vapours vary in their flammability and explosivity. The relative severity of an explosion from a particular component mixed with air is indicated by a variety of characteristics of the gas including the lower and upper explosive limits (LEL/UEL), the auto ignition temperature (AIT), the minimum ignition energy (MIE), the limiting oxygen concentration (LOC) and the maximum experimental safe gap (MESG).

For ease of assessment, pure gases have been classified into groups of similar reactivity. Various groupings exist, depending on the source of the information but the two most widely used are shown below in tables 1 and 2. In these tables, the gas group is indicated by a range of MESG values and a typical test gas is identified for the purpose of type testing a flame arrester.

If a flame arrester is satisfactorily flame tested for a given gas group then it is suitable for use with any other gas in the same group or a lower group. For example in practice propane is normally used for testing the lowest level of flame arrester and success here means that it may be used for any Group IIA gas as well as for Group I or methane. Other standards also group gases in a similar but not identical manner.

表 1 歐盟氣體分類標準 *European Standard Gas Groups*

氣體分組	MESG (mm)	測試氣體	測試氣體濃度 (% v/v in Air)	典型的氣體
IIA	>0.90	Propane	4.2	Methane, alkanes, alcohols, acetone, benzene
IIB3	>0.65	Ethylene	6.5	Ethylene, ethylene ether
IIB	>0.50	Hydrogen	45.0	Ethylene oxide, Butadiene
IIC	<0.50	Hydrogen	28.5	Hydrogen

表 2 美國氣體分類標準 *US Equivalent Gas Groups*

氣體分組	MESG (mm)	典型的氣體
D	>0.75	Methane, alkanes, alcohols, acetone, benzene
C	>0.45	Ethylene, ethylene oxide
B	<0.45	Hydrogen
A	-	Acetylene



火焰防阻器的種類 Types of Flame Arrester

火焰防阻器的構造

火焰防阻器通常包含外殼、防火元件及連接口以供安裝在管道或設備。

防火元件是用來熄滅火焰，其主要的構造通常是類似過濾器或多孔體的元件，具有可供氣體流動的小孔徑，但可防阻火焰通過。當火焰通過防火元件的過濾元件時會被分解為細微的小火焰，再利用防火元件極大的熱傳能力來冷卻及熄滅火焰。

構成過濾元件的材料包含彎曲的金屬帶、梭織鐵絲網、燒結材料、填充粉體及蜂窩構造材料等。由於其構造可能會造成壓力下降或流動的阻塞。為了減緩所增加的流動阻力，防火元件面積通常比管路橫截面積大。較大的防火元件會有較好的熱容量。

火焰防阻器的外殼可與防火元件的外殼一體成型或為分離元件。後者，利用固定元件加以連結固定。其連接口通常是法蘭或牙口接頭，以利與管道接合。



Construction of a Flame Arrester

A flame arrester comprises housing, an element and connection(s) to secure it to pipe work or equipment.

The flame arresting element is a device that quenches the flame in a form of "filter" or "porous media" that provides small apertures through which the process gas will flow but will prevent flame transmission through the element. The flame front is broken down in the "filter" or "porous media" into smaller flamelets which are cooled by the large heat capacity of the element and the flame is extinguished consequently.

Materials used for the "filter" or "porous media" element include crimped metal ribbons, woven wire gauze, sintered materials, packed powders and honeycomb materials. The element will cause a pressure drop or an obstruction to process flow because of its construction. In order to moderate this increased resistance to flow, the element area is usually larger than the cross sectional area of the pipe work. Larger elements also have a greater heat capacity for flame cooling.

The housing of the flame arrester can be integral to or separate from the element housing. In the latter case it is joined together with fastenings. The end connections are usually either flanged or screwed fittings to match the adjacent pipe work.

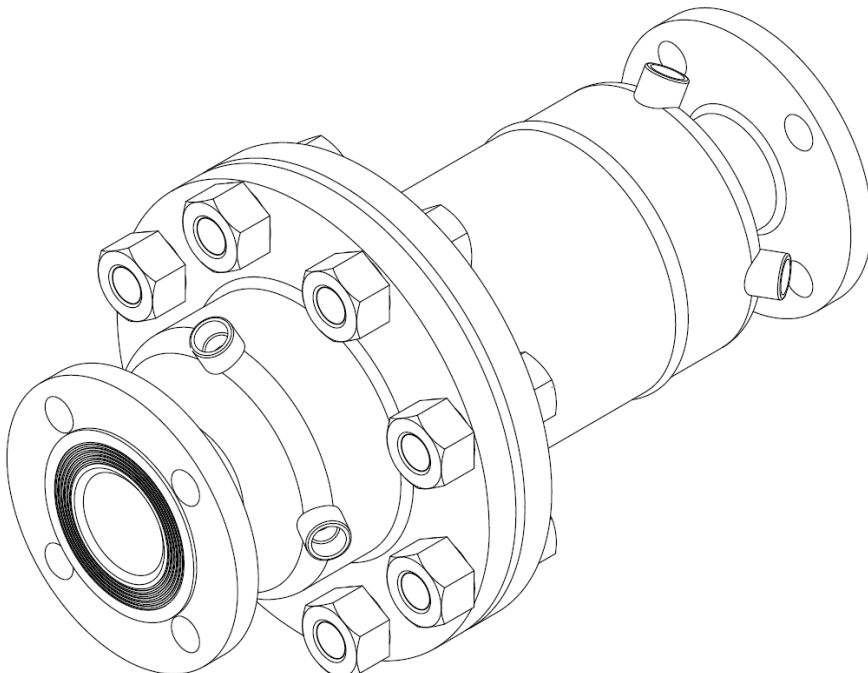

法蘭洩漏防護型火焰防阻器

法蘭洩漏防護型 (FLP) 火焰防阻器裝置於管線之法蘭外側將法蘭包覆，以防止法蘭洩漏時火焰進入管道或容器。沒有防水罩的法蘭洩漏防護型火焰防阻器，可被安裝於任何方向，但是不建議向下安裝，因為這將會使得能量蓄積而導致回火；使用有防水罩的火焰防阻器，必須以向上的方向安裝。(中華民國新型專利M429791)

Flange Leakage Protection Flame Arresters

Flange Leakage Protection (FLP) flame arresters are fitted to a pipe line for flange leakage protection to prevent flames from outside entering the pipe or vessel. Without a weather-hood, they may be mounted in almost any orientation, but inverted mounting is not recommended as it increases the risk of heat being trapped thus causing a flash back. With a weather-hood incorporated, they should be fitted in a conventional upward orientation.



管線末端火焰防阻器

管線末端 (End of Line, EOL) 火焰防阻器裝置於管線末端或容器出口，以防止火焰進入管道或容器，而非防止管道或容器內的火焰溢出。沒有防水罩的火焰防阻器，可被安裝於任何方向，但是不建議向下安裝，因為這將會使得能量蓄積而導致回火；使用有防水罩的火焰防阻器，必須以垂直方向安裝，並使用於兩區及下雪區。

End-of-line Flame Arresters

End-of-line (EOL) flame arresters are fitted to the end of a pipe line or exit to a vessel to prevent flames from entering, and not, as is sometimes believed, to prevent the flame exiting the pipe or vessel. Without a weather-hood, they may be mounted in almost any orientation, but inverted mounting is not recommended as this increases the risk of heat being trapped thus causing a flash back. With a weather-hood incorporated, they should be fitted in a conventional vertical orientation and be used outside exposed to rain and snow.

火焰防阻器的種類 Types of Flame Arrester

管線型火焰防阻器

管線型火焰防阻器裝置於管道系統，主要用於保護其下游設備。以下配置圖為典型的情況，但是也有可能火焰的點火源與氣體同向流動。若火焰可來自任何一個方向，則應使用雙向火焰防阻器。管線型火焰防阻器依其使用條件可為爆燃型或爆炸型火焰防阻器。管道的方向通常不成問題，除非是流體中夾帶液體，且會收集於火焰防阻器中，此時可使用偏心火焰防阻器，以利收集及排放液體。

In-line flame arresters

In-line flame arresters are fitted in piping systems to protect downstream equipment. The layout shown below is typical although it is also possible that the source of ignition could cause the flame to travel with the gas flow. If the flame could come from either direction then a bi-directional flame arrester is required. In-line flame arresters can be either deflagration or detonation arresters depending on the conditions under which they are to be used. Pipe orientation is usually not a problem unless liquid is entrained in the gas flow and would tend to collect in the arrester. In such situations, an eccentric flame arrester housing may be fitted to allow collection and drainage of the liquid.



容積防護型火焰防阻器

當火焰是存在於一個截面積大於火焰防阻器或排氣管道的容器內時，目的若是要防止火焰離開該容器時，使用任何元件、管線末端火焰防阻器或管線型火焰防阻器都需要很小心，因為，它將面對無法預測的火焰防阻器條件，且通過火焰防阻器的熱氣體流量可能遠超過火焰防阻器的標準測試條件。

雖然這屬於一種密閉的爆燃環境，但是經過標準測試的燃爆型火焰防阻器可能還是無法確保令人滿意的性能；因此，要提供可信任的產品，唯一的解決辦法就是以實際或模擬的操作條件加以測試驗證。



Pre-volume flame arresters

Pre-volume flame arresters are designed to protect systems in which a flame may start within a container whose cross sectional area is somewhat larger than the flame arrester element or the vent pipe and the desire is to prevent the flame leaving the container. They may be simply an element, an end-of-line arrester or an in-line arrester. Extreme care must be taken when considering such a situation as it is not possible to predict the conditions that the flame arrester will have to handle because the volume of hot gases passing through the arrester will exceed the volumes produced for conventional in-line arrester flame testing.



Although the conditions will tend to produce a confined deflagration it is possible that an arrester that has been satisfactorily tested under confined deflagration arrester conditions laid down in a product standard will not be satisfactory. Therefore, the only solution to ensure total confidence in the product specified is to test it under actual or simulated operational conditions.

Liquid product and hydraulic flame arresters

液體產品火焰防阻器可將管道中的部分液體捕集，使氣體以氣泡方式通過，並將任何火焰熄滅。流體型火焰防阻器內部含有能自動調節液位的水，使得氣體通過時，也是同樣的以氣泡方式通過，使得任何火焰都能被熄滅。這種技術特別適用於夾帶粒狀物的髒氣體。

Liquid product and hydraulic flame arresters

Liquid product flame arresters trap some of the liquid flowing in a pipe so that the gases may bubble through it but any flame is extinguished. Hydraulic arresters contain water whose level is automatically maintained. Similarly gases may bubble through it but any flame would be extinguished. This technique is particularly suited to a dirty gas flow with particulate matter entrained within it.



火焰防阻器的使用 Application of a Flame Arrester

火焰防阻器大部分時間就僅是維持在定位並容許氣體通過，但在極端少見的狀況下必須能夠即使將火焰熄滅。火焰防阻器的重要特徵就是會產生壓降，或是由於它的建構方法對流體流動會造成相當程度的阻礙，這會造成一些使用上的問題；在設計和選擇火焰防阻器時，必須考慮系統對應的流速和可容許的壓降，同時必須在發生意外點燃時能提供適當的保護。

確定可能的點火源及要保護的對象以後，接著就是要將火焰防阻器盡可能安裝接近點火源。如果容許火焰沿著管道蔓延，火焰將會因為升溫及燃燒產物的作用快速的加速，而變得不易阻擋及熄滅。最後爆燃可能發生轉化成爆炸，並對設備更具破壞性。如果有一個以上的火源，就應安裝一個以上的火焰防阻器。

使用檢測元件及自動切斷系統 提供額外的保護

如果火焰經火焰防阻器抑制後，可燃性混合氣體還不斷洩漏，則其將會在元件附近穩定繼續燃燒，這將導致該元件繼續升溫，並可能導致火焰繼續傳播。在這種情況下，可能需要使用專門開發且經過測試的產品；或者加裝火焰感測器與氣體供應源切斷系統連線，一旦偵測到火焰就切斷氣體供應。

特殊應用條件

火焰防阻器通常被設計使用於常溫、常壓；如需應用於其他條件，請諮詢經驗豐富及訓練有素的豐映科技股份有限公司工程師的意見。當在寒冷使用條件的元件，尤其是安裝在管線末端時，可能因被凍結而堵塞。高溫及高壓會增加火焰防阻器的負荷，需要實際或模擬的操作條件加以測試驗證。如果火焰防阻器應用於腐蝕性或危險物質，可使用特殊材料製造或加上適當的表面塗裝。在大多數的情況下，使用不鏽鋼元件及碳鋼或不鏽鋼外殼就足夠了。

定期檢查和維護

火焰防阻器必須定期檢查和維護；如果已知或相信已發生回火，就應該檢查火焰防阻器是否有損壞。防火元件的小孔隙或零件很容易被灰塵堵塞，而使壓降增大，損壞或變形的防火元件應該立即更換。通常防火元件可以清潔後重新使用。火焰防阻器正確使用，將可使用很多年。

For the majority of the time that a flame arrester is in place, it will be required to permit the process gas to flow and will be expected to extinguish flames on extremely rare occasions instantly. A key characteristic of a flame arrester is the pressure drop or degree of obstruction to process flow due to its method of construction. This can lead to problems and it is essential that the design and sizing of the flame arrester are matched to the process flow rates and pressure drop permitted in the system whilst ensuring that adequate protection is provided against accidental ignition.

Having defined where the possible source or sources of ignition may occur and exactly what is to be protected, and then the objective is to place the flame arrester as close as possible to the ignition source. If a flame is allowed to proceed down a pipe then, in general, it will accelerate because of pressure build up resulting from the increased temperature and volume of burnt products and be progressively more difficult to stop. Ultimately a deflagration may undergo transition to a detonation and therefore become significantly more destructive to equipment. Where there is more than one source of ignition then it may be appropriate to install more than one flame arrester.

Detection and cut off systems for Additional Protection

If the flammable mixture continues to flow after flame transmission has been prevented the flame may stabilise on or near the element and continue to burn. This will cause the element to continue to heat up and can lead to flame transmission. Specially developed and tested products are required for such eventualities and often a flame sensor is linked to a gas supply cut off system to extinguish the flame soon after detection.

Special Application Conditions

Flame arresters are usually designed for use at ambient temperature and pressure. Please consult RESI's experienced and trained engineers for advice if other conditions are encountered. Beware of cold conditions where the element, particularly in an end of line unit, may freeze over and block. Higher temperatures and pressures put increased load on the flame arrester and testing under actual or simulated conditions may be required. If corrosive or dangerous substances are present the flame arrester may be constructed using special materials or with special coating. In the majority of cases, a stainless steel element together with a carbon or stainless steel housing would be adequate.

Inspection and Maintenance

Regular inspection and maintenance of flame arresters is essential. If a flashback is known or believed to have occurred then the arrester should be inspected for damage. The small cells or components of the element are prone to collect dirt and become blocked thus increasing the pressure drop. Damaged or dirty elements should be replaced. Often it is possible to clean the element for re-use. Correctly treated, a flame arrester can give many years of service.



ATALAS FLAME ARRESTER

Atlas Energy Systems Limited (Samoa) <http://www.resi.com.tw>
 21F, #218, Section 1, Wen-Xin Road, Nan-Tun District,
 Taichung City, Taiwan 40865
 Tel: +886-4-24726600 E-mail: service@resi.com.tw

Flame Arrester Data Sheet

Company Name		For the attention of: (and department)	
Address			
Telephone No.		Fax No.	
E-mail		Web Page	http://
1. Enquiry No.			
2. Analysis of gases and/or vapour (% by volume) or tank contents			
3. Flash point			
4. Maximum flow rate	m ³ /min		
5. Maximum static pressure at arrester	Pascal		
6. Acceptable pressure drop	Pascal		
7. Maximum temperature at arrester	°C		
8. Minimum temperature at arrester	°C		
9. In-line or end of line type and size	<input type="checkbox"/> In-Line	<input type="checkbox"/> End of Line	NB Size:
10. If in-line, distance of arrester from source of ignition	m		
11. Type of flange or thread	<input type="checkbox"/> ANSI-#____ <input type="checkbox"/> JIS-____K <input type="checkbox"/> RF <input type="checkbox"/> FF <input type="checkbox"/> Other: <input type="checkbox"/> Thread		
12. Material of housing	<input type="checkbox"/> Carbon Steel <input type="checkbox"/> SUS-304 <input type="checkbox"/> SUS-316 <input type="checkbox"/> Hastalloy <input type="checkbox"/> Other:		
13. Material of element	<input type="checkbox"/> Carbon Steel <input type="checkbox"/> SUS-304 <input type="checkbox"/> SUS-316 <input type="checkbox"/> Hastalloy <input type="checkbox"/> Other:		
14. Storage tank capacity (if applicable)	M ³		
15. Maximum filling and emptying rates for storage tank	M ³ /min		
16. Advise if endurance burning on the element is possible			
17. Special Requirements / comments			
18. If previous supply identical, please indicate order no.			
Customer's signature		Ref:	
Position in organization		Date	

ATLAS internal record:

Customer		Date	
Order #		Due Date	
Model #		Quantity	
Connection		Gas	
Housing		Class	
Material		MESG	
Cell Component Design			

Preparing flame arresters data sheet

Excerpt of EN-12874 / ISO-12874

To help the manufacturers and users decide which flame arrester is the most suitable for their application, the following should be considered :

- 1. Service**
Provide a brief description of the intended use for the flame arrester.
- 2. Analysis of gases or vapors**
Provide full details of flammable and non-flammable components; which will allow the correct flame arrester design, explosion group and choice of materials to be made.
- 3. Molecular weight or density of gas or vapor**
This will allow an equivalent air flow rate to be calculated for pressure drop determination.
- 4. Flow rate**
This should be in volumetric terms, or sufficient information provided to allow a volumetric flow rate to be calculated. For storage tank applications the inbreathing and out-breathing requirements should be given, or sufficient information on the tank type, pressure resistance shape, dimensions, fill and empty rates provided to enable these parameters to be calculated.
- 5. Temperature ranges**
For both design and operating conditions, the maximum and minimum temperatures will allow the correct element and mechanical design of the flame arrester housing to be made.
- 6. Pressure ranges**
For both design and operating conditions, the maximum and minimum pressure will allow the correct flame arrester element and mechanical design of the flame arrester housing to be made. The maximum pressure at which a flammable mixture can ignite in the process should be highlighted if this is different to the normal operating pressure. For storage tank applications the pressure and vacuum requirements should be given.
- 7. Allowable pressure drop**
This will enable the correct flame arrester configuration to be provided and is determined from the volumetric flow rate.
- 8. Type**
Specify in-line, end-of-line, pre-volume, short time or endurance burning safe and stable / unstable detonation as required. For in-line types details of the piping between the flame arrester and possible source of ignition should be supplied in the form of a dimensioned sketch or isometric drawing.
- 9. Orientation**
State the intended orientation of the flame arrester.
- 10. Pipe size**
The nominal size of the connecting pipe work should be stated.
- 11. Connection type**
Provide details of the flanged or screwed connections.
- 12. Housing material**
State the preferred material of construction; this may be checked by the manufacturer from an evaluation of the mixture composition and operating conditions.
- 13. Element material**
State the preferred material of construction; this may be checked by the manufacturer from an evaluation of the mixture composition and operating conditions.
- 14. Construction**
Care should be taken when using materials such as aluminum or plastics which can cause incentive sparking or electrostatic charging.
- 15. Documentation**
State documentation requirements.

火焰防阻器資料表填寫指南

摘要自 EN-12874 / ISO-12874

為了協助使用者及製造商選擇最適合的火焰防阻器，以下因素必須加以考慮：

- 1. 用途**
提供火焰防阻器的用途說明。
- 2. 氣體成分分析**
提供全部可燃性氣體及非可燃性氣體的詳細組成，以利選擇適當的火焰防阻器設計，判定氣體爆炸群組及選擇適當材料。
- 3. 氣體的分子量或密度**
可供計算氣體體積流速及計算壓損。
- 4. 流量**
提供體積流率，或提供足夠的資料以利計算體積流率。對於貯存槽應用場合，需要提供氣體呼吸吸入或流出的流率，或提供貯存槽種類、呼吸閥設計、流體抽取或填入的流速，以利計算呼吸量。
- 5. 使用溫度範圍**
設計及操作條件的最高及最低操作溫度，以利正確製造防火元件及火焰防阻器外殼機械設計。
- 6. 使用壓力範圍**
設計及操作條件的最高及最低操作壓力，以利正確製造防火元件及火焰防阻器外殼機械設計。若使用壓力不是常壓，必須述明使用壓力。應用於貯存槽時，壓力或真空壓力必須提供。
- 7. 可容許壓差**
使得火焰防阻器可以正確的設計，且可以由體積流率計算之。
- 8. 火焰防阻器種類**
指定火焰防阻器種類，若使用於管線中，管線及火焰防阻器、點火源都需要提供說明，或繪製 3D 示意圖。
- 9. 使用方向**
說明操作火焰防阻器的方向性。
- 10. 管徑**
必須說明連接管線的公稱管徑。
- 11. 連接方式**
詳細說明法蘭或螺牙接口細節。
- 12. 外殼材料**
說明希望的外殼材料，由製造商評估混合物組成及操作條件。
- 13. 元件材料**
說明希望的材料，由製造商評估混合物組成及操作條件。
- 14. 製造**
使用鋁或塑膠製品，要特別小心可能會產生火花或靜電放電的問題。
- 15. 文件需求**
說明文件需求。

豐映科技股份有限公司

RESI Corporation / Atlas Energy Systems Ltd

地址：台中市文心路一段 218 號 21 樓

電話：(04) 2472-6600； 傳真：(04) 2475-5872

21F, #218, Sec. 1, Wen-Xin Road, Tai-Chung City, Taiwan, R. O. C.

TEL: +886-4-2472-6600 FAX: +886-4-2475-5872

E-Mail: service@resi.com.tw <http://www.resi.com.tw>